

User Manual

Blood Pressure Monitor

Model: TMB-2284-B

Arm Type

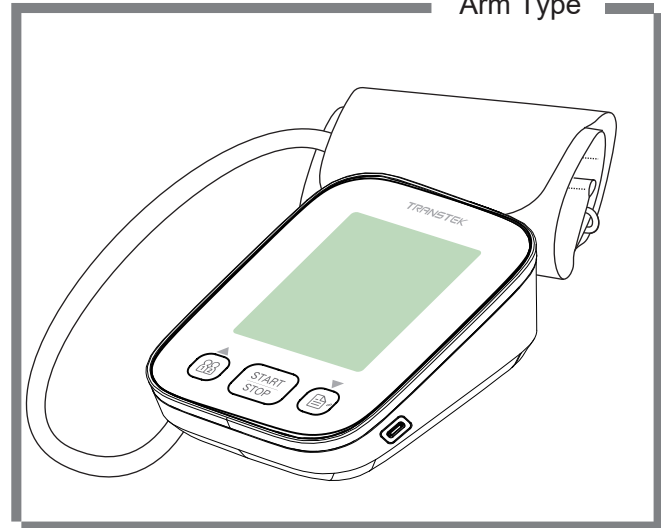

- Thank you very much for selecting TRANSTEK Blood Pressure Monitor TMB-2284-B.
- Please read the user manual carefully and thoroughly so as to ensure the safe usage of this product, keep the manual well for further reference in case you have problems.

Table of Contents

INTRODUCTION.....	2
• General Description	
• Indications for Use	
• Measurement Principle	
• Receiving and Inspecting your Monitor	
• Safety Information	
• LCD Display Signal	
• Monitor Components	
• List	
BEFORE YOU START.....	8
• Choice of Power Supply	
• Installing and Replacing the Batteries	
• Setting the Date and Time	
• Setting a user ID	
• Pair a smart device with the monitor	
MEASUREMENT.....	14
• Applying the cuff	
• Start the Measurement	
DATA MANAGEMENT.....	18
• Recall the Records	
• Delete the Records	
INFORMATION FOR USER.....	22
• Tips for measurement	
• Maintenances	
ABOUT BLOOD PRESSURE.....	24
• What are systolic pressure and diastolic pressure?	
• What is the standard blood pressure classification?	
• Irregular pulse rate detector	
• Why does my blood pressure fluctuate throughout the day?	
• Why do I get a different blood pressure at home compared to the hospital?	
• Is the result the same if measuring on the right arm?	
TROUBLESHOOTING.....	26
SPECIFICATIONS.....	27
AUTHORIZED COMPONENT	28
CONTACT INFORMATION.....	28
EU DECLARATION OF CONFORMITY.....	39
EMC GUIDANCE.....	30

♥ General Description

Thank you for selecting TRANSTEK arm type blood pressure monitor (TMB-2284-B). The monitor features blood pressure measurement, pulse rate measurement and the result storage. The warranty period is two years.

Readings taken by the TMB-2284-B are equivalent to those obtained by a trained observer using the cuff and stethoscope auscultation method.

This manual contains important safety and care information, and provides step by step instructions for using the product.

Read the manual thoroughly before using the product.

Features:

- 59x72.5 mm Digital LCD display with white backlight
- Maximum 199 records per each user
- 3rd technology: Measuring during inflation

♥ Indications for Use

This Blood Pressure Monitor is a digital monitor intended for use in measuring blood pressure and pulse rate with arm circumference ranging from 16cm to 36cm (about 6 $\frac{1}{8}$ "-14 $\frac{1}{8}$ "), 22cm to 32cm (about 8 $\frac{3}{4}$ "-12 $\frac{1}{2}$ "), 22cm to 42cm (about 8 $\frac{3}{4}$ "-16 $\frac{1}{2}$ ") or 22cm to 45cm (about 8 $\frac{3}{4}$ "-17 $\frac{3}{4}$ ").

It is intended for at least 3 years of age or older and indoor use only.

♥ Measurement Principle















This product uses the Oscillometric Measuring method to detect blood pressure. Before every measurement, the unit establishes a "zero pressure" equivalent to the atmospheric pressure. Then it starts inflating the arm cuff, meanwhile, the unit detects pressure oscillations generated by beat-to-beat pulsatile, which is used to determine the systolic and diastolic pressure, and also pulse rate.

♥ Receiving and Inspecting your Monitor

Check that the device packaging has not been tampered with and make sure that all contents are present. Before use, ensure that there is no visible damage to the device or accessories and that all packaging material has been removed. If you have any doubts, do not use the device and contact your retailer or the specified Customer Services address.

♥ Safety Information

The signs below might be in the user manual, labeling or other component. They are the requirement of standard and using.

	Manufacturer		Type BF applied part
	Date of manufacture		Direct Current
			Serial Number
	Recyclable		Medical Device
	For indoor use only		Class II Equipment
	Refer to instruction manual/booklet To signify that the instruction manual/ booklet must be read. Note: The background color of the symbol is blue.		
	Caution Indicates that caution is necessary when operating the device or control close to where the symbol is placed, or that the current situation needs operator awareness or operator action in order to avoid undesirable consequences.		
	The symbol indicates that the product should not be discarded as unsorted waste but must be sent to separate collection facilities for recovery and recycling.		
	CE marking indicates that a product has been assessed by the manufacturer and deemed to meet EU safety, health and environmental protection requirements. It is required for products manufactured anywhere in the world that are then marketed in the EU.		
	Authorized representative in the European Community/ European Union		

Precaution

- * This device is intended for indoor, home use and is not intended for self-use in public areas.
- * This device is portable, but it is not intended for use during patient transport.
- * This device is not suitable for continuous monitoring during medical emergencies or operations.
- * This device is intended for non-invasive measuring and monitoring of arterial blood pressure. It is not intended for use on extremities other than the arm, or for any purpose other than obtaining a blood pressure measurement.
- * This device is intended for patients who are at or over 3 years old. Do not use this device on neonates or infants.
- * Consult with your physician before using this monitor if you suffer from the following conditions: common arrhythmias such as premature ventricular beats or atrial fibrillation; peripheral arterial disease; pregnancy; preeclampsia; implantation with electrical devices; undergoing intravascular therapy; arteriovenous shunt or mastectomy. Please note that any of these conditions may affect measurement readings, in addition to patient motion, trembling or shivering.
- * Do not use this device for diagnosis or treatment of any health problems or diseases. Please consult with your physician first whether the blood pressure or pulse rate readings can be used as an input in determining clinical actions. Please note that clinical actions can only be determined by the physician, otherwise it may lead to delayed treatment or other dangerous situations.
- * If you are taking medication, consult your physician to determine the proper time to measure your blood pressure.
- * This device may be used only for the intended use described in this manual, the manufacturer shall have no liability for any incidental, consequential, or special damages caused by misuse or abuse.
- * Please use the device under the environment which is provided in the user manual. Otherwise, the performance and lifetime of the device will be impacted and reduced.
- * The device may require up to 30 minutes to warm up / cool down from the minimum/ maximum storage temperature before it is ready for use.
- * The blood pressure monitor, its adapter, and the cuff are suitable for use within the patient environment.
- * Do not wash the cuff in a washing machine or dishwasher!
- * The device contains sensitive electronic components. To avoid measurement errors, avoid taking blood pressure measurements near a strong electromagnetic field radiated interference signal or electrical fast transient/burst signal.
- * Wireless communication equipment, such as wireless home network devices, mobile phones, cordless telephones and their base stations, walkie-talkies may cause interference that may affect the accuracy of measurements. A minimum distance of 1 foot (30 cm) should be kept from such devices during a measurement.
- * Blood Pressure Monitor is intended for use by medical staffs and lay persons, and patient is also an intended user or operator.

⚠ Caution

- * Do not attempt to repair the unit yourself if it malfunctions. Only have repairs carried out by authorized service centers.
- * It is recommended that the performance should be checked after repair, maintenance, and every two years of use, by retesting the requirements in limits of the error of the cuff pressure indication and air leakage (testing at least at 50 mmHg and 200 mmHg). Please contact manufacturer or distributor for authorized service personnel.
- * Store your device, cuff and adapter in a clean and dry place, protect it against extreme moisture, heat, lint, dust and direct sunlight. Never place any heavy objects on it.
- * Make sure the rubber tube of the cuff is not squeezed, stretched, or kinked during storage.
- * Dispose of accessories, detachable parts, and the device according to the local guidelines.

Warning

- * Do not apply the cuff on an arm that has an intravenous drip or a blood transfusion attached.
- * Do not kink, fold, stretch, compress, or otherwise deform the tube during measuring, as the cuff pressure might continuously increase, which could prevent blood flow and result injury.
- * Taking blood pressure measurements too frequently could disrupt blood circulation and cause injuries.
- * Do not apply cuff to areas on patient where skin is delicate or damaged. Check cuff site frequently for irritation.
- * Do not place the cuff on the arm of a person whose arteries or veins are undergoing medical treatment, i.e. intra-vascular access or intra-vascular therapy or an arteriovenous (A-V) shunt, which could disrupt blood circulation and cause injuries.
- * Do not place the cuff on the arm on the same side of a mastectomy (especially when lymph nodes have been removed). It is recommended to take measurements on the unaffected side.
- * Do not wrap the cuff on the same arm to which another monitoring device is applied. One or both devices could temporarily stop functioning if you try to use them at the same time.
- * Please check (for example, by observation of the limb concerned) that the operation of the device does not result in prolonged impairment of patient blood circulation.
- * On the rare occasion of a fault causing the cuff to remain fully inflated during measurement, loosen and remove the cuff immediately. Prolonged high pressure applied to the arm (cuff pressure >300 mmHg or constant pressure >15 mmHg for more than 3 minutes) might lead to bruising and discolored skin.
- * Do not use this device with high-frequency (HF) surgical equipment at the same time.
- * This device is not used in conjunction with oxygen rich environments, not intended for use with flammable anaesthetics, not intended for use in conjunction with flammable agents.
- * Do not touch output of the batteries/adapter and the user simultaneously.
- * The power cord is considered the disconnect device for isolating this equipment from supply mains.
- * Do not position the equipment so that it is difficult to reach or disconnect.
- * Do not use this device if you are allergic to polyester, nylon, or plastic.
- * Only use accessories approved by manufacturer. Using unapproved accessories might cause damage to the unit and injure users.
- * If you experience discomfort during a measurement, such as pain in the arm or other complaints, press the Power button immediately to release the air from the cuff.
- * Do not use the device while under maintenance, or being serviced.
- * The air tube poses a risk of strangulation. Furthermore, the small parts of product and batteries present a choking hazard if swallowed. They should therefore always be kept away from infants/children.
- * Sensor degradation or looseness may reduce performance of device or cause other problems.

Notice

- * You can use this device to take your own measurement, no third-party operator is required.
- * Adapter is specified as a part of ME EQUIPMENT.
- * At the request of authorized service personnel, circuit diagrams, component part lists, descriptions, and calibration procedures will be made available by the manufacturer or distributor.
- * The expected lifetime of the cuff may vary by the frequency of washing, skin condition, and storage state.
- * Please report to the manufacturer and the competent authority of the Member State / the FDA in which you are established about any serious incident that has occurred in relation to this device.

♥ LCD display signal

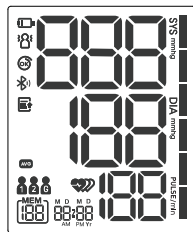

SYMBOL	DESCRIPTION	EXPLANATION
SYS	Systolic blood pressure	High pressure result
DIA	Diastolic blood pressure	Low pressure result
PULSE/min	Pulse display	Pulse in beats per minute
mmHg	mmHg	Measurement Unit of the blood pressure
	User ID	User 1/2/Guest
	Current Time	Time(year.month.day:hour.minute)
	Pulse rate	Pulse rate detection during measurement
	Hand shaking	Hand shaking makes results inaccurate
	Battery Indicator	Indicate the current battery
	Irregular pulse rate	Irregular pulse rate
	Data transmitting	Data is transmitting
	Cuff wearing	The cuff is secured
	Blood pressure level	Indicate blood pressure level
	Bluetooth icon	The bluetooth icon blinks when the bluetooth is working
	Average value	The average value of the latest three groups blood pressure value
	Memory Query	Indicate it is in the memory mode and which group of memory it is.

♥ Monitor Components

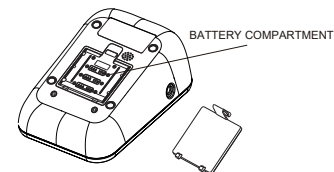
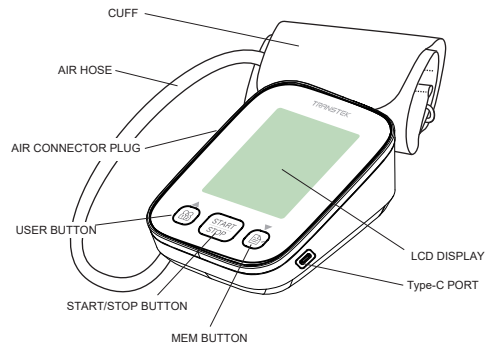

♥ List

1. Blood Pressure Monitor (TMB-2284-B)



3. 4×AAA batteries(Optional!)



2. Cuff (Type BF applied part)



Upper arm cuff:16-36cm
Upper arm cuff:22-32cm or
Upper arm cuff:22-42cm or
Upper arm cuff:22-45cm.

4. AC Adapter(Optional!)



5. User manual

♥ Choice of Power Supply

1. Battery powered mode:
6VDC 4×AAA batteries (Optional!)

2. AC adaptor powered mode:
5V \equiv 1A (Optional!)
(Please use the AC adapter which is authorized by the manufacturer!)

Please unplug the adaptor to depart from the using utility power.

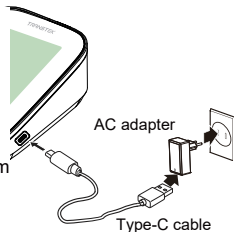

⚠ CAUTION

In order to get the best effect and protect your monitor, please use the right batteries and special power adapter which complies with local safety standard.

♥ Installing and Replacing the Batteries

- Open the battery cover.
- Install the batteries by matching the correct polarity, as shown.
- Replace the battery cover.

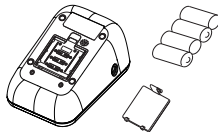

Replace the batteries whenever the below happen

- The shows
- The display is dim.
- The display does not light up

⚠ CAUTION

- New and used batteries, or different types of batteries shall not be used together.
- Remove batteries if the device is not likely to be used for some time.
- Do not heat or deform the batteries, or dispose of them in fire.
- Batteries should not be disposed of with household waste.
- Please check with your local authority for battery recycling advice.

♥ Setting Date and Time

It is important to set the clock before using your blood pressure monitor, so that a time stamp can be assigned to each record that is stored in the memory. (The setting range of the year :2022—2052 time format: 12H/24H)

1. When the monitor is off, press and hold the “START/STOP” button, it will display the bluetooth symbol first.
No operation within 60s or Press the “START/STOP” button again, it will skip Bluetooth pairing and enter the [Year] setting.
Press the “USER” or “MEM” button to change the year.
Press and hold the “USER” button to quickly advance the years.
Press and hold the “MEM” button to quickly go backwards through the years.

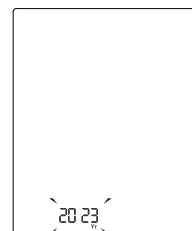
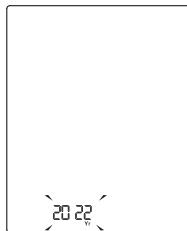

2. Press the “START/STOP” button to confirm the year, then the [date format] will flash. Press the “USER” or “MEM” button to switch the date format between [month/day] and [day/month].

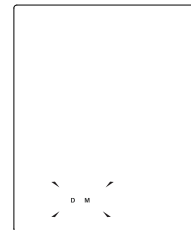

3. Press the “START/STOP” button to confirm the date format, then the month will flash. Repeat the same steps to set the month, day, time format, hour and minute.

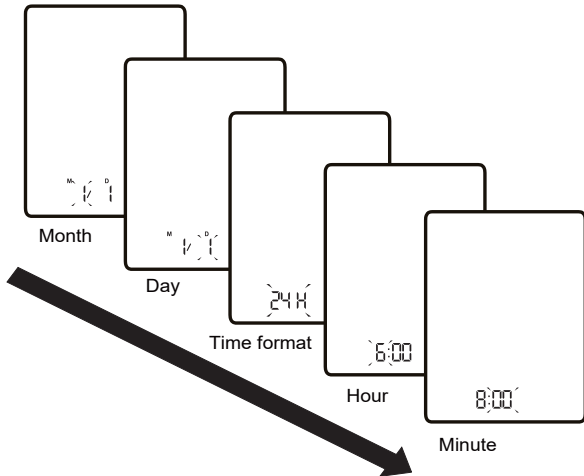

4. After the minute is set, the LCD will display “do nE” and then turn off after several seconds.

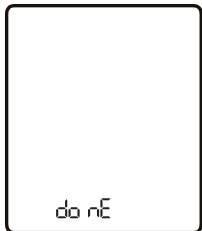

♥ Setting a user ID

There are 3 user ID available. The user and , each with 199 memory spaces, are designed for 2 different people to save the measured values separately. The user , no memory space, is reserved for guest.

1. When the monitor is off, press the “USER” button to display the current user ID and flash. Press the “USER” button to switch the user ID between the user , and .

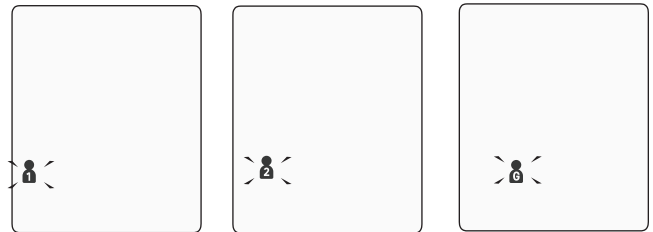

2. Press the “START/STOP” button to confirm the selected user ID, then the monitor will enter the measurement automatically.

♥ Pair a smart device with the monitor

You are the intended operator of this blood pressure monitor. You can measure your blood pressure and then save and send measurement data to a smart device (such as smartphone or tablet) with Bluetooth wireless connectivity and application.

1. Turn on the Bluetooth and the app on your smart device.

Make sure both are ON when pair-up is proceeding.

2. When the monitor is off, press and hold the “MEM” button to start pair-up, the bluetooth symbol will flash.

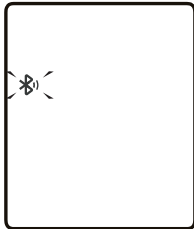

3. If successful, the bluetooth symbol will not flash any more and the monitor will automatically shut off after several seconds.

Note

1. The date and time on your monitor will automatically be set after paired with your smart device successfully.
2. The device can also enter the Bluetooth pairing by long pressing the “START/STOP” button.

If **unsuccessful** within 60 seconds, it is judged timeout and the monitor will shut off.

Specifications for Bluetooth Transmission

Bluetooth	Throughput	2.5K-5K
	Latency	50ms
	PER	< 10%
	Operating Frequency	2402-2480MHz
	Transmission Power	0±2dBm
	Transmission Distance	10m

Note:

1. The necessary Quality of Service (QoS) is fully considered here for wirelessly enabled functions.
2. Interference may occur in the vicinity of equipment marked with the following symbol . And TMB-2284-B may interfere the vicinal electrical equipment.
3. Keep the monitor at least 20 centimeters away from the human body (especially the head) when data transmission is proceeding after measurement.
4. To enable the data transmission function, this device shall be paired to an appropriate BT mobile terminal.

Warning

About a wireless communication interference

The monitor operates in the unlicensed ISM band at 2.4 GHz. In case it is used around the other wireless devices including microwave and wireless LAN, which operate at the same frequency band as the monitor, there is a possibility that interference occurs between the monitor and such other devices. If such interference occurs, please stop the operation of other devices or relocate the monitor before using it or do not use it around the other wireless devices.

List of compatible devices:

For iOS devices:

The operating system must be iOS 13.0 or more.

For Android devices:

The operating system must be Android 5.0 or more.

♥ Applying the cuff

Only use a cuff that has been approved by the manufacturer for this device model. Before use, please confirm if it fits your arm circumference.

1. Remove all jewelry, such as watches and bracelets from your left arm.

Note: If your doctor has diagnosed you with poor circulation in your left arm, use your right arm.

2. Roll or push up your sleeve to expose the skin. Make sure your sleeve is not too tight.

3. Hold your arm with your palm facing up and tie the cuff on your upper arm, align the Artery indicator ϕ with the main Artery (on the inside of your arm).

Note: Locate the main Artery by pressing with 2 fingers approximately 2 cm above the bend of your elbow on the inside of your left arm. Identify where the pulse can be felt the strongest, that is your main Artery!

4. Make sure the bottom edge of the arm cuff is 2 to 3 cm above the inside elbow. Then wrap the cuff securely.

Note: The cuff should be snug but not too tight. You should be able to insert one finger between the cuff and your arm.

5. Sit upright in a comfortable chair with your back against the backrest of the chair. Keep your feet flat and your legs uncrossed.

Place your arm resting comfortably on a flat table. The cuff worn on your arm should be placed at the same level as your right atrium of the heart.

6. Take 5-6 deep breaths and let's start measuring!

Helpful tips:

- Take the measurement in a silent room.
- Rest for 5 minutes before a measurement.
- Wait at least 3 minutes before another measurement. This allows your blood circulation to recover.
- Be relaxed and do not move and talk during the measurement procedure.
- For a meaningful comparison, try to measure under similar conditions. For example, take daily measurements at approximately the same time, on the same arm, or as directed by a physician.

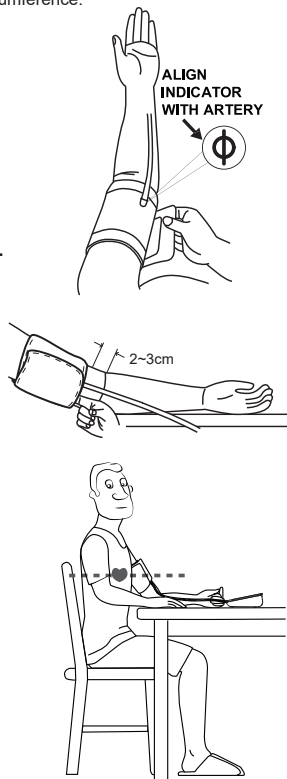

♥ Start the Measurement

You can use your monitor without pairing to a smart device. To pair your monitor with a smart device refer to the foregoing chapters.

1. When the monitor is OFF, press the “START/STOP” button, it will finish the whole measurement automatically, save and transmit the measurement data for the selected user. (Take User 1 for example.)

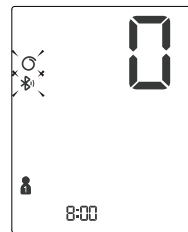

Adjust the zero.

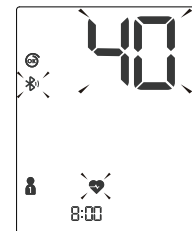

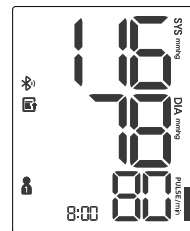

Cuff wrap ok.
Inflating and measuring.





Display and save the measurement result.



Note

- Any time, to stop the measurement, press the “START/STOP” button.
- If you don't pair with the device or don't keep the app ON, the bluetooth symbol  will flash during the measurement.
- If there are untransmitted data, the symbol  will display during the measurement.



2. Press the “START/STOP” button to turn off the monitor, or it will shut off after about 1 minute.

3. If your monitor is already paired with your smart device and both Bluetooth and app are ON, when the measurement completed, the measurement result will start transmitting. (only user 1 and 2 available)

If **successful**, the symbol “” will disappear first, after several seconds, “” will also disappear, and then the monitor will turn off automatically.

If **unsuccessful** within 60 seconds, it is judged timeout and the monitor will shut off. In the case of a data transmission failure, up to 199 measurements are saved on the device for user  or  and will be sent when a successful connection is achieved.

4. About the irregular pulse rate and excessive body motion during the measurement.

- During a measurement, If an irregular pulse rate is detected, the symbol  will display in the measurement result. See page 24 for more information.
- During a measurement, when the excessive body motion, especially of the arm the cuff is worn is detected, the symbol  will flash about 5 seconds and detect again. If it is no longer detected, the symbol will disappear; If still detected, the symbol  will final display in the measurement result.

Note

The measured blood pressure reading may not be accurate if this symbol is displayed.

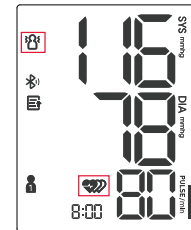

♥ Recall the Records

1. When the monitor is off, press the “MEM” button, the user ID will blink.
2. Press the “USER” or “MEM” button to switch the user ID between user 1 and 2. press the “START/STOP” button to confirm the selected user ID.
3. Then the LCD will display the average value of last 3 readings. When the records are less than three groups, it will display the latest record. (Example shown below for User 1.)
4. Press the “USER” or “MEM” button to display the next record.

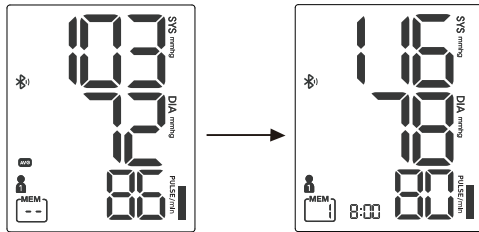

Date and Time will display alternately.

Note

- If there is untransmitted data, the symbol displays on the record.
- The latest record (1) is shown first. Each new measurement is assigned to the first (1) record. All other records are pushed back one digit (e.g., 2 becomes 3, and so on), and the last record (199) will be dropped from the list.

♥ Delete the Records

Delete the records by following the steps below.

A: Delete one record (Example shown below for User 1)

1. Enter the memory recall mode as described in the previous section “Recall the records”, find out the record you want to delete.
2. Press and hold the “MEM” button about 3 seconds, the LCD will display “dEL y” and blink.
3. Press the “START/STOP” button to confirm the deletion, the LCD will display “done” and then the previous record will be displayed.

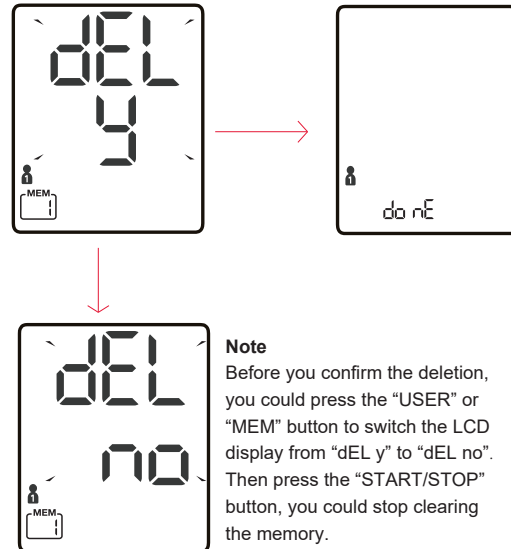

Note

Before you confirm the deletion, you could press the “USER” or “MEM” button to switch the LCD display from “dEL y” to “dEL no”. Then press the “START/STOP” button, you could stop clearing the memory.

B: Delete all records (Example shown below for User 1)

1. Enter the memory recall mode as described in the previous section "Recall the records".
2. Press and hold the "USER" and "MEM" button about 3 seconds, the LCD will display "dEL AL" and blink.
3. Press the "START/STOP" button to confirm the deletion, the LCD will display "donE".

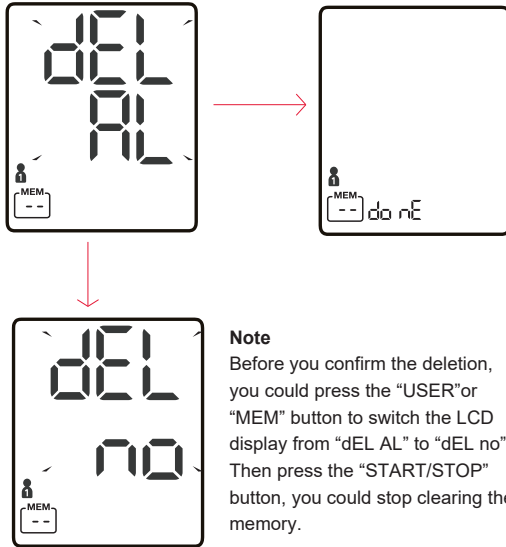
**Note**

Before you confirm the deletion, you could press the "USER" or "MEM" button to switch the LCD display from "dEL AL" to "dEL no". Then press the "START/STOP" button, you could stop clearing the memory.

4. Once deleted, your readings cannot be restored. The LCD will display "--" like the following picture.

Press the "START/STOP" button to turn off the monitor, otherwise it will power off automatically after about 1 minute.

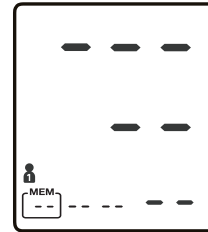

♥ Tips for Measurement

Measurements may be inaccurate if taken in the following circumstances.



Within 1 hour
after dinner or drinking



Immediate measurement
after tea, coffee, smoking



Within 20 minutes
after taking a bath



When talking or moving your fingers



In a very cold environment



When you want to discharge urine



♥ Maintenance

In order to get the best performance, please follow the instructions below.

1. Cleaning Process:

- Step 1: Make sure to switch off and unplug the device prior to cleaning.
 Step 2: Use a soft cloth wetted with soapy water to clean the cuff first, and then use a soft cloth wetted with clear water to remove residual soap until there is no visible residual contaminants. Attention shall be paid to avoid liquid invasion into the cuff.
 Step 3: Use a dry soft cloth to wipe the cuff, in order to remove residual moisture.
 Step 4: Dry the cuff at a well-ventilated place after cleaning.

2. Disinfection Process:

- Step 1: Make sure to switch off and unplug the device prior to disinfection.
 Step 2: Use a soft cloth wetted with 70% isopropanol to disinfect the cuff for about 3 minutes. Attention shall be paid to avoid liquid invasion into the cuff.
 Step 3: Use a clean dry cloth or towel to wipe off the disinfectant until there is no visible residue.
 Step 4: Dry the cuff at a well-ventilated place after disinfection.

• Suggestion:

Frequency of Cleaning and Disinfection:
 For single patient multiple use, it's recommended to clean the device surface once a month or whenever it's necessary.
 For multiple patient multiple use, it's recommended to clean the device every time before and after usage. Maintenance procedures shall be taken as per instruction.

♥ What are systolic pressure and diastolic pressure?

When ventricles contract and pump blood out of the heart, the blood pressure reaches its maximum value in the cycle, which is called systolic pressure. When the ventricles relax, the blood pressure reaches its minimum value in the cycle, which is called diastolic pressure.

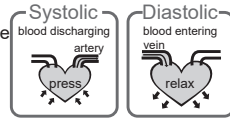

♥ What is the standard blood pressure classification?

The blood pressure classification published by World Health Organization (WHO) and International Society of Hypertension (ISH) in 1999 is as follows:

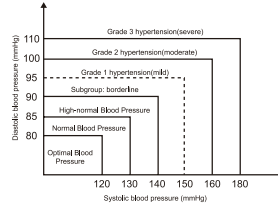

⚠ CAUTION

Only a physician can tell your normal BP range. Please contact a physician if your measuring result falls out of the range. Please note that only a physician can tell whether your blood pressure value has reached a dangerous point.

Blood Pressure (mm Hg) \ Level	Optimal	Normal	High-normal	Mild	Moderate	Severe
SYS	<120	120-129	130-139	140-159	160-179	≥180
DIA	<80	80-84	85-89	90-99	100-109	≥110

♥ Irregular Pulse Rate Detector

An irregular pulse rate will be detected if there is an irregular pulse rhythm while measuring systolic and diastolic blood pressure. When measurements were performed, the monitor will record all pulse intervals and calculate the average. If two or more pulse intervals were recorded, and the difference between each interval and the average is larger than ±25% of the average; or if four or more pulse intervals were recorded, and the difference between each interval and the average is larger than ±15% of the average value, the irregular pulse symbol will be displayed along with measurement results.

⚠ CAUTION

The appearance of the IPR icon indicates that a pulse irregularity consistent with an irregular pulse rate was detected during measurement. Usually this is NOT a cause for concern. However, if the symbol appears often, we recommend you seek medical advice. Please note that the irregular pulse rate detector results cannot be used directly for clinical judgement. Please seek medical advice from professionals before making any medical decisions.

♥ Why does my blood pressure fluctuate throughout the day?

1. Individual blood pressure varies multiple times everyday. It is also affected by the way you tie your cuff and your measurement position, so please take the measurement under the same conditions.
2. If the person takes medicine, the pressure will vary more.
3. Wait at least 3 minutes for another measurement.

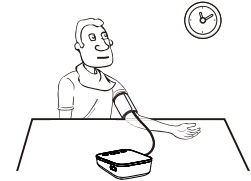

♥ Why do I get a different blood pressure at home compared to the hospital?

The blood pressure is different even throughout the day due to weather, emotion, exercise etc. Also, there is the "white coat" effect, which means blood pressure usually increases in clinical settings.

What you need to pay attention to when you measure your blood pressure at home:



- If the cuff is tied properly.
- If the cuff is too tight or too loose.
- If the cuff is tied on the upper arm.
- If you feel anxious.
- Taking 2-3 deep breaths before beginning will be better for measuring.
- Advice: Relax yourself for 4-5 minutes until you calm down.

♥ Is the result the same if measuring on the right arm?

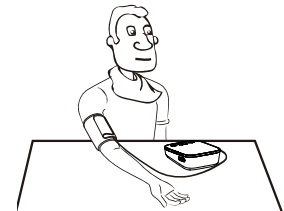
It is ok for both arms, but there will be some different results for different people. We suggest you measure the same arm every time.



If any abnormality arises during use, please check the following points:

PROBLEM	SYMPTOM	CHECK THIS	REMEDY
No power	Display can not light up.	Batteries are depleted.	Replace with new batteries.
		Batteries are inserted incorrectly.	Insert the batteries correctly.
		Adapter is inserted incorrectly.	Insert the AC adapter correctly.
High Battery	bAt H shows	The battery is too high.	Replace with new batteries.
Low Battery	bAt Lo &  shows	The battery is too low.	Replace with new batteries.
Error message	E 1 shows	The cuff is not wrapped or wrapped incorrectly, or the cuff air plug is loose.	Refasten the cuff and insert air tube plug correctly then measure again.
	E 2 or  shows	Excessive body motion (such as shaking of the arm with the cuff on) or weak Pulse is detected.	Relax for 5 minutes. and then keep still, measure again.
	E 3 shows	Pulse is not detected during measuring.	Loosen the clothing on the arm and measure again.
	E 4 shows	The measurement failed.	Relax for 5 minutes and measure again.
	EExx shows	Hardware error (XX can be some digital symbol, such as 1, 2, etc.)	Turn off monitor and measure again. If EEx still appears on the display, please contact the retailer or our customer service.
	USb Err shows	The voltage of the blood pressure monitor is high or low.	Replace with the authorized adapter.
Warning message	out shows	Out of measurement range	Relax for a moment and then measure again. If the problem persists, contact your physician.

NOTE: If the product still does not work, contact Customer Service. Under no circumstance should you disassemble or attempt to repair the unit by yourself.

External dimensions	Approx.100.3mmx132.3mmx47.1mm
Display mode	Digital LCD V.A. 59 mm × 72.5 mm
Weight	Approx.273 g (Excluding the batteries and cuff)
Measurement mode	Oscillographic testing mode
Mode of operation	Continuous operation
Measurement range	Rated cuff pressure: 0 mmHg~299 mmHg Measurement pressure: SYS: 60 mmHg ~ 230 mmHg DIA: 40 mmHg ~ 130 mmHg Pulse value: (40-199) beat/minute
Accuracy	Static Pressure: 5°C-40°C within ±3mmHg Pulse value: ±5% Clinical validation: Mean difference within ±5mmHg; Standard deviation ≤8mmHg
Normal working condition	A temperature range of: +5°C to +40°C A relative humidity range of 15% to 90%, non-condensing, but not requiring a water vapour partial pressure greater than 50 hPa An atmospheric pressure range of 700 hPa to 1060 hPa
Storage & transportation condition	Temperature:-20°C to +60°C A relative humidity range of ≤ 93%, non-condensing, at a water vapour pressure up to 50 hPa An atmospheric pressure range of 500 hPa to 1060 hPa
Measurement perimeter of the upper arm	About 16-36 cm or 22-32 cm or 22-42 cm or 22-45cm
Degree of protection	Type BF applied part
Protection against ingress of water	IP21 It means the device could be protected against solid foreign objects of 12,5mm Φ and greater, and against vertically falling water drops.
Device Classification	Battery Powered Mode: Internally Powered ME Equipment AC Adapter Powered Mode: Class II ME Equipment
Expected Lifetime	Device: 3 years or 30,000 measurements (may vary based on usage conditions) Cuff: 10000 times Alkaline battery: About 200-300 times
Types of use/reuse	Multiple patient multiple use

WARNING: No modification of this equipment is allowed.

♥ Authorized Component

Please use the authorized adapter. (Optional!)

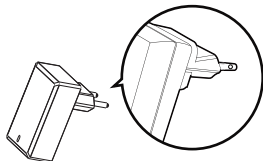

Adapter

Type: BLJ06L050100U-V
 BLJ06L050100U-S
 BLJ06L050100U-B

Input: 100-240V, 50-60Hz, 0.2A max
 Output: 5V \equiv 1000 mA

♥ Contact Information

For more information about our products, please visit
www.transtekcorp.com.

Manufactured by: Guangdong Transtek Medical Electronics Co., Ltd.

Company: Guangdong Transtek Medical Electronics Co., Ltd.

Address: Zone A, No.105, Dongli Road, Torch Development District,
 528437 Zhongshan, Guangdong, China

♥ EU Declaration of Conformity

Hereby we,
 Name of Manufacturer: Guangdong Transtek Medical Electronics Co., Ltd.
 Address: Zone A, No.105 Dongli Road, Torch Development District, 528437
 Zhongshan, Guangdong, China

declare that this DoC is issued under our sole responsibility for the
 below equipment.

Product Name:	Blood Pressure Monitor
Model name:	TMB-2284-B
Software:	A01
Accessories:	Cuff AC1636-01, AC2232-10, AC2242-17, AC2242-31, AC2245-05

comply with the following directives and regulations:

2014/53/EU (The Radio Equipment Directive)

For the evaluation of the compliance with these Directives and Regulations,
 the following standards/requirements were applied:

Safety Article3.1(a)	IEC 60601-1:2005+AMD1:2012+AMD2:2020 IEC 60601-1-11:2015+AMD1:2020
EMC Article3.1(b)	EN 301 489-1 V2.2.3 EN 301 489-17 V3.2.4
Radio Article3.2	EN 300 328 V2.2.2
Health Article3.1(a)	EN 62479:2010

Person responsible for making this declaration

Print name/Title: Ken Zhai/Product manager *Ken Zhai*

Guangdong Transtek Medical Electronics Co.,Ltd

♥ EMC Guidance

The ME EQUIPMENT or ME SYSTEM is suitable for home healthcare environments.

Essential performance:

Accuracy of measuring blood pressure and pulse rate

Measurement Range	Systolic pressure: 60-230 mmHg Diastolic pressure: 40-130 mmHg Pulse: 40-199 beats/minute
Rated Cuff Pressure	0-299 mmHg (0-39.9 kPa)
Accuracy	Static Pressure: 5 °C -40 °C within ±3mmHg Pulse value: ±5% Clinical validation: Mean difference within ±5mmHg; Standard deviation ≤8mmHg

The Basis Safety of the Blood Pressure Monitor (TMB-2284-B) is as following:
Deviation from normal operation that poses an unacceptable risk to the patient or operator.

Warning: Don't be near the active HF surgical equipment and the RF shielded room of an ME system for magnetic resonance imaging, where the intensity of EM disturbances is high.

Warning: Use of this equipment adjacent to or stacked with other equipment should be avoided because it could result in improper operation. If such use is necessary, this equipment and the other equipment should be observed to verify that they are operating normally.

Warning: Use of accessories, transducers and cables other than those specified or provided by the manufacturer of this equipment could result in increased electromagnetic emissions or decreased electromagnetic immunity of this equipment and result in improper operation.

Warning: Portable RF communications equipment (including peripherals such as antenna cables and external antennas) should be used no closer than 30 cm (12 inches) to any part of the equipment including cables specified by the manufacturer. Otherwise, degradation of the performance of this equipment could result.

Technical description:

1. all necessary instructions for maintaining BASIC SAFETY and ESSENTIAL PERFORMANCE with regard to electromagnetic disturbances for the expected lifetime.

2. Guidance and manufacturer's declaration -electromagnetic emissions and Immunity

Table 1

Guidance and manufacturer's declaration - electromagnetic emissions	
Emissions test	Compliance
RF emissions CISPR 11	Group 1
RF emissions CISPR 11	Class [B]
Harmonic emissions IEC 61000-3-2	Class A
Voltage fluctuations / flicker emissions IEC 61000-3-3	Comply

Table 2

Guidance and manufacturer's declaration – electromagnetic Immunity		
Immunity Test	IEC 60601-1-2 Test level	Compliance level
Electrostatic discharge (ESD) IEC 61000-4-2	±8 kV contact ±2 kV, ±4 kV, ±8 kV, ±15 kV air	±8 kV contact ±2 kV, ±4 kV, ±8 kV, ±15 kV air
Electrical fast transient/burst IEC 61000-4-4	±2 kV for power supply lines ±1 kV signal input/output 100 kHz repetition frequency	±2 kV for power supply lines Not Applicable 100 kHz repetition frequency
Surge IEC61000-4-5	±0.5 kV, ±1 kV differential mode ±0.5 kV, ±1 kV, ±2 kV common mode	±0.5 kV, ±1 kV differential mode Not Applicable
Voltage dips, short interruptions and voltage variations on power supply input lines IEC 61000-4-11	0% U _T ; 0,5 cycle. At 0°, 45°, 90°, 135°, 180°, 225°, 270° and 315°. 0% U _T ; 1 cycle and 70% U _T ; 25/30 cycles; Single phase: at 0°. 0% U _T ; 250 / 300 cycle	0% U _T ; 0,5 cycle. At 0°, 45°, 90°, 135°, 180°, 225°, 270° and 315°. 0% U _T ; 1 cycle and 70% U _T ; 25/30 cycles; Single phase: at 0°. 0% U _T ; 250 / 300 cycle
Power frequency magnetic field IEC 61000-4-8	30 A/m 50 Hz / 60 Hz	30 A/m 50 Hz / 60 Hz
Conducted RF IEC61000-4-6	3 V 0,15 MHz – 80 MHz 6 V in ISM and amateur radio bands between 0,15 MHz and 80 MHz 80% AM at 1 kHz	3 V 0,15 MHz – 80 MHz 6 V in ISM and amateur radio bands between 0,15 MHz and 80 MHz 80% AM at 1 kHz
Radiated RF IEC61000-4-3	10 V/m 80 MHz – 2,7 GHz 80% AM at 1 kHz	10 V/m 80 MHz – 2,7 GHz 80% AM at 1 kHz
NOTE U _T is the a.c. mains voltage prior to application of the test level.		

Table 3

Guidance and manufacturer's declaration - electromagnetic Immunity								
Radiated RF IEC61000-4-3 (Test specifications for ENCLOSURE PORT IMMUNITY to RF wireless communications equipment)	Test Frequency (MHz)	Band (MHz)	Service	Modulation	Maximum Power (W)	Distance (m)	IEC 60601-1-2 Test Level (V/m)	Compliance level (V/m)
	385	380-390	TETRA 400	Pulse modulation 18 Hz	1.8	0.3	27	27
	450	430-470	GMRS 460, FRS 460	FM ± 5k Hz deviation 1 kHz sine	2	0.3	28	28
	710	704-787	LTE Band 13, 17	Pulse modulation 217 Hz	0.2	0.3	9	9
	745							
	780							
	810							
	870	800-960	GSM 800/900, TETRA 800, IDEN 820, CDMA 850, LTE Band 5	Pulse modulation 18 Hz	2	0.3	28	28
	930							
	1720							
	1845	1700-1990	GSM 1800; CDMA 1900; GSM 1900; DECT; LTE Band 1, 3, 4, 25; JNITS	Pulse modulation 217 Hz	2	0.3	28	28
	1970							
2450	2400-2570	Bluetooth, WLAN, 802.11 b/g/n, RFID 2450, LTE Band 7	Pulse modulation 217 Hz	2	0.3	28	28	
5240	5100-5800	WLAN 802.11 a/n	Pulse modulation 217 Hz	0.2	0.3	9	9	
5500								
5785								